

FEATURES

- 7" Display
- 65536 True Color
- Water-Proof and Vibration-Proof: IP65-Rated Front Panel, IP62-Rated Overall
- Hanging Mounting, Rack Mounting
- High-Speed Process with 800MHz RISC CPU
- High Resolution up to 800 x 480 Pixels
- Easy to Use
- 3 Position Enable Switch, Emergency Stop Switch
- 10 Programmable Keys



DESCRIPTION

The KNC-HMI-SZ7ES is a Water-Proof and Vibration-Proof HMI product that will make your application run smoothly and efficiently. This KNC-HMI-SZ7ES HMI comes with a 65536 color display mode that gives your touch screen rich color and incomparable resolution. The KNC-HMI-SZ7ES has a “splash-proof” IP65-rated front panel an overall ingress protection rating of IP62 which protects it from falling drops of water. It is totally protected against dust ingress. With the simple, convenient and powerful configuration software, the user can master its design method and create first-class programs efficiently.

DIMENSIONS

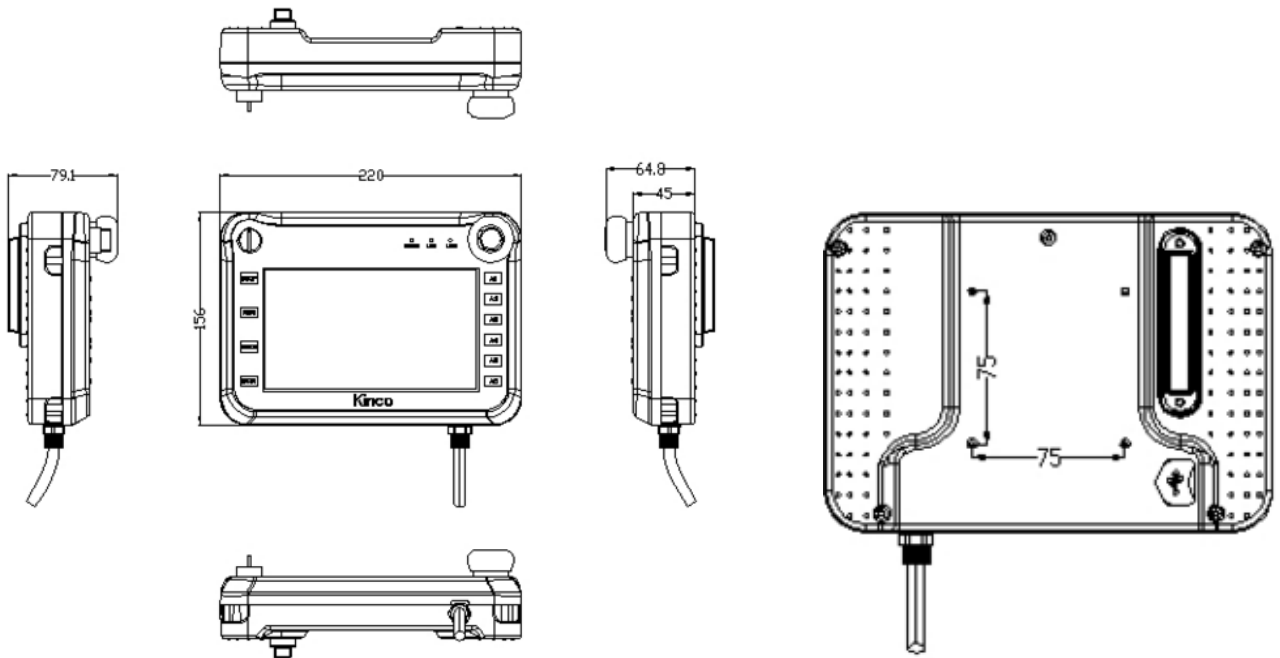

Dimensions are in (mm)

L011501

Performance Specification	
Display	7" TFT
Resolution	800 x 480 Pixels
Color	65536 Colors
Backlight	LED
Brightness	250 cd/m ²
Backlight Life	50000 Hrs
Touch Panel	4-Wire Precision Resistance Network
Programmable Button	10
Programmable LED	2
Emergency Stop Button	1
3-Position Rotary Switch	1
Handheld Switch	1
Processor	800MHz RISC
Memory	128 MB FLASH + 64MB SDRAM
Recipe Memory & RTC	256KB + RTC
Expandable Memory	1 USB Host (≤16G)
Ethernet	1
Program Download	RS232 , USB , Ethernet
COM Port	Ethernet , RS232
Electrical Specification	
Rated Power	8 W
Rated Voltage	24 VDC (In-Built Isolated Power Supply)
Input Range	17~32VDC
Power Down Allowed	<3 ms
Insulation Resistance	> 50M Ω @ 500 VDC
Dielectric Strength Test	500 VAC 1 Minute
Electric Cable	5m
Structure Specification	
Shell Color	Black
Shell Material	ABS + Plastic
Dimensions(mm)	220 x 156 x 45mm
Installation	Rack Mounting or Hanging Mounting
Environment Specification	
Operating Temperature	0°~50° C
Operating Humidity	10~90% RH (Non-Condensing)
Storage Temperature	-10°~60° C
Storage Humidity	10~90% RH (Non-Condensing)
Shockproof Test	10 ~ 25Hz (X,Y,Z Direction, 2G / 30 Minutes)
Cooling Method	Natural Air Cooling
Certification	
Degree of Protection	Front Panel: IP65; Whole Body: IP62
CE Certification	EN61000-6-2:2005 and EN61000-6-4:2007
FCC Compatibility	Complies with FCC Class A

L011501